

Upright Cabinets

# T-49F-HC

 Upright Foodservice Freezer, 2 Full Solid Swing Doors



Dimensions		Build		Technical	
External Width (mm)	1375	Door Description	2 Full Solid Swing Doors	Temperature Holding	-23°C
External Depth (mm)	750	Exterior Construction	Stainless steel front, aluminium sides & rear	Refrigerant	R290
External Height (mm)	2074	Interior Construction	Clear coated aluminium, stainless steel base	Voltage / Frequency / Phase	220-240V/50Hz/1
Exclusions	Depth does not include 13 mm for rear access panel.	Air Intake Position	Front	Amps	5.5
Net Volume (Litres)	914	Ventilation Position	Rear	60Hz model Amps	4.6
Gross Volume (Litres)	1388	Clearance Required	26 mm rear, zero sides	Wattage	1265
Supplied Shelves	8	Cord Length (Meters)	2.74	60Hz model Wattage	1058
Shelf Size (L x D mm)	624 x 569	Internal Lighting	LED	Climate Class	4
Internal Net Height (mm)	1300	Standard w/ Locks	standard	Operating Statement	Regular Duty: This appliance is intended for use in ambient temperatures up to 30°C.
Unpackaged Weight (kg)	207			Testing Standard	EN 16825
Packaged Weight (kg)	218			EEC	D
Packaged Dimensions (W x D x H mm)	1486 x 902 2134			EEL	75
Supplied Supports	ø 64 mm castors (83 mm height)			kWh/24hr	12.2
				kWh/Annum	4478
				Defrost Type	Auto



Specifications subject to change without notice.  
 Technical data above related to energy use based on testing of 50Hz or Dual Frequency models  
 Chart dimensions rounded up to the next whole millimeter (inches rounded up to the 1/8")

UK & Ireland [0800 783 2049](tel:08007832049)  
 EMEA [+41 61 563 07 05](tel:+41615630705)  
 Australia [+61 2 9619 9999](tel:+61296199999)

[TFIUK@truemfg.com](mailto:TFIUK@truemfg.com)  
[TrueCHCustomerService@truemfg.com](mailto:TrueCHCustomerService@truemfg.com)  
[TrueRefAus@truemfg.com](mailto:TrueRefAus@truemfg.com)



# T-49F-HC

🇬🇧 Upright Foodservice Freezer, 2 Full Solid Swing Doors

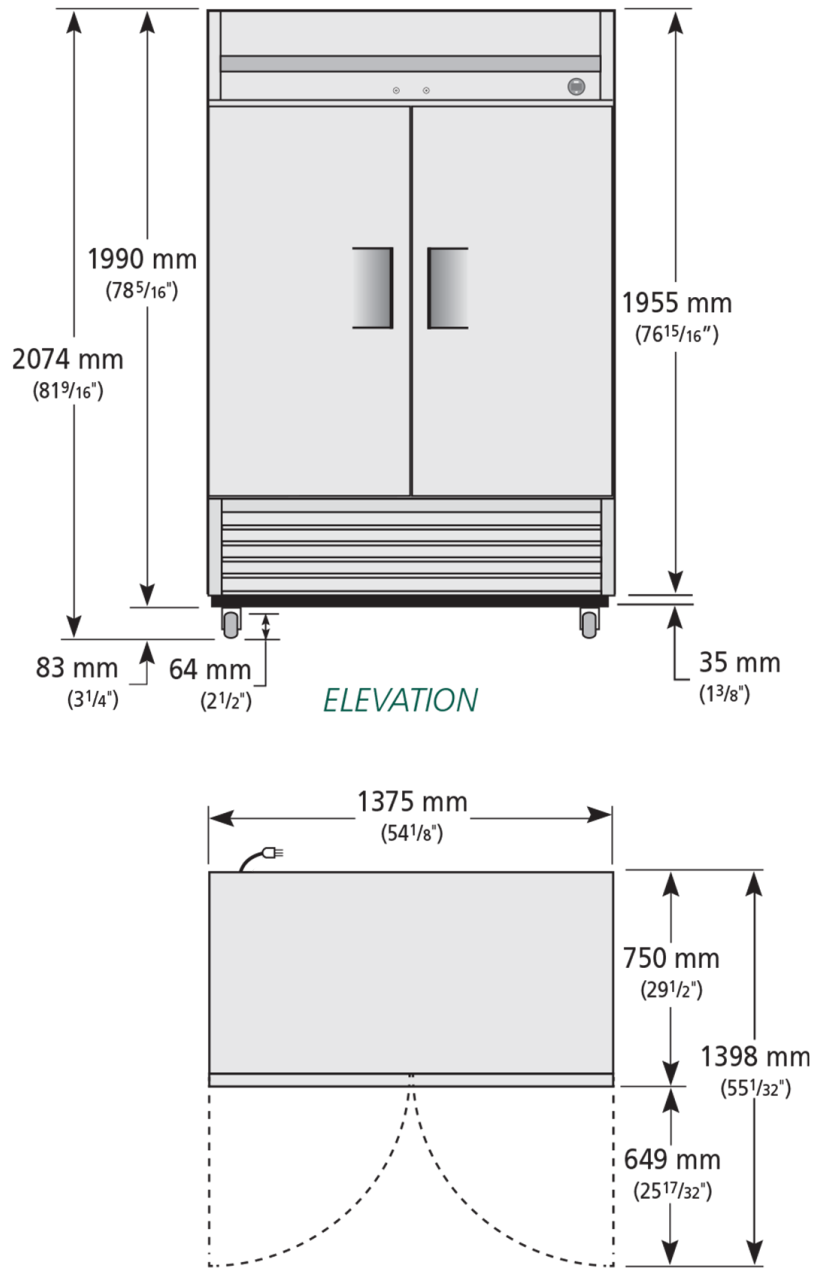

Specifications subject to change without notice.  
Technical data above related to energy use based on testing of 50Hz or Dual Frequency models  
Chart dimensions rounded up to the next whole millimeter (inches rounded up to the 1/8")

UK & Ireland 0800 783 2049  
EMEA +41 61 563 07 05  
Australia +61 2 9619 9999

[TFIUK@truemfg.com](mailto:TFIUK@truemfg.com)  
[TrueCHCustomerService@truemfg.com](mailto:TrueCHCustomerService@truemfg.com)  
[TrueRefAus@truemfg.com](mailto:TrueRefAus@truemfg.com)

