



# VACUUM PACKING MACHINE SE-308 230/50-60/1

Tabletop model. 8 m<sup>3</sup>/h. -- mm



1141083



## OPTIONAL

- Vacuum packing bags.
- External vacuum kit for Vac-Norm, containers and accessories.
- Support for liquid packaging.
- Additional filling plates.

## SPECIFICATIONS

Pump capacity: 8 m<sup>3</sup>/h  
 Pump capacity (60 Hz): 8 m<sup>3</sup>/h  
 Bar length: -- mm  
 Total loading: 450 W  
 Vacuum pressure (maximum): 2 mbar  
 Electrical supply: 230 V / 50-60 Hz / 1 ~ (3.1 A)  
 Plug: EU (SCHUKO 2P+G)

### Internal dimensions

- ✓ Width: 330 mm
- ✓ Depth: 360 mm
- ✓ Height: 155 mm

### External dimensions (WxDxH)

- ✓ Width: 384 mm
- ✓ Depth: 465 mm
- ✓ Height: 405 mm

Net weight: 36.1 Kg

Noise level (1m.): 75 dB(A)  
 Background noise: 32 dB(A)

### Crated dimensions

540 x 478 x 465 mm  
 Gross weight: 43.1 Kg

## SALES DESCRIPTION

-- mm sealing bar.  
 8 m<sup>3</sup>/h Busch vacuum pump.  
 Vacuum controlled by sensor.

- ✓ Powered by Busch.
- ✓ Vacuum controlled by sensor.
- ✓ Vacuum PLUS.
- ✓ Digital keyboard.
- ✓ Control panel equipped with display indicating the exact vacuum percentage.
- ✓ "Pause" button to marinate food.
- ✓ Safe liquid packing thanks to sensor control.
- ✓ Double seal.
- ✓ Cordless sealing bar.
- ✓ Bag-sealing programme.
- ✓ Pulse-controlled decompression.
- ✓ Vac-Norm ready with Automatic decompression.
- ✓ Stainless steel body and chamber. Deep-drawn chamber.
- ✓ Damped transparent lid of highly durable polycarbonate.
- ✓ Dry-oil programme for drying the pump.
- ✓ Working hours counter for oil changes.
- ✓ Safety system with protection against vacuum failure.
- ✓ NSF-listed model.

## INCLUDES

- ✓ Sensor controls.
- ✓ BUSCH pump.
- ✓ Up to 10 seconds of extra vacuum pull.
- ✓ NSF approved.
- ✓ Soft air function.
- ✓ Clear methacrylate lid.
- ✓ Dry oil cycle.
- ✓ Filling plate.

FOOD PRESERVATION AND SOUS-VIDE  
 VACUUM PACKING MACHINES · SENSOR LINE

product sheet  
 updated 28/03/2023



SAMMIC, S.L.  
 Basarte, 1 - 20720 Azkoitia  
 www.sammic.com



# VACUUM PACKING MACHINE SE-308 230/50-60/1

Tabletop model. 8 m<sup>3</sup>/h. -- mm



1141083

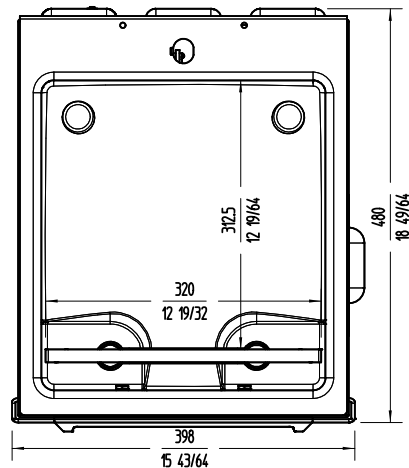
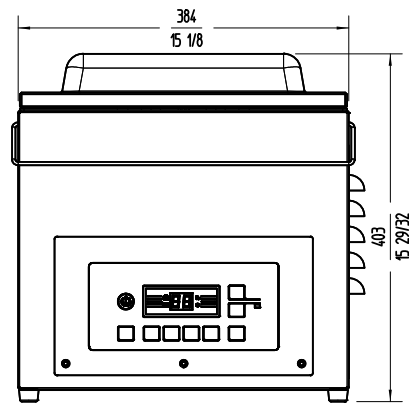
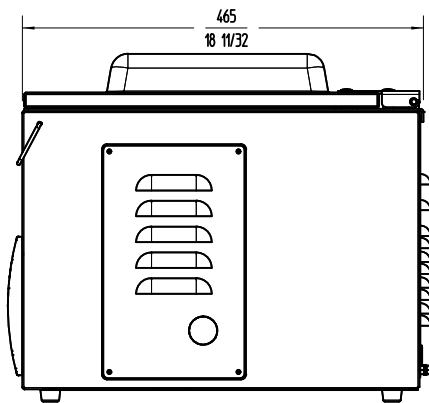

FOOD PRESERVATION AND SOUS-VIDE  
VACUUM PACKING MACHINES · SENSOR LINE



[www.sammic.co.uk](http://www.sammic.co.uk)

Food Service Equipment Manufacturer

Unit 2, Trevanah Road  
Troon Industrial Park  
LE4 9LS - Leicester

[uksales@sammic.com](mailto:uksales@sammic.com)  
Tel.: +44 0116 246 1900



Project	Date
Item	Qty
Approved	

product sheet  
updated 28/03/2023