



# VACUUM PACKING MACHINE SE-520 L 230/50-60/1

Tabletop model. 20 m³/h. 555 mm



1141143



## SALES DESCRIPTION

555 mm sealing bar.  
20 m³/h Busch vacuum pump.  
Vacuum controlled by sensor.

- ✓ Powered by Busch.
- ✓ Vacuum controlled by sensor.
- ✓ Vacuum PLUS.
- ✓ Digital keyboard.
- ✓ Control panel equipped with display indicating the exact vacuum percentage.
- ✓ "Pause" button to marinate food.
- ✓ Safe liquid packing thanks to sensor control.
- ✓ Double seal.
- ✓ Cordless sealing bar.
- ✓ Bag-sealing programme.
- ✓ Pulse-controlled decompression.
- ✓ Vac-Norm ready with automatic decompression.
- ✓ Stainless steel body and chamber. Long-shaped, deep-drawn chamber.
- ✓ Damped transparent lid of highly durable polycarbonate.
- ✓ Dry-oil programme for drying the pump.
- ✓ Working hours counter for oil changes.
- ✓ Safety system with protection against vacuum failure.

## INCLUDES

- ✓ Sensor controls
- ✓ Up to 10 seconds of extra vacuum pull
- ✓ Soft air function
- ✓ Dry oil cycle
- ✓ BUSCH pump
- ✓ NSF approved
- ✓ Clear methacrylate lid
- ✓ Filling plate

## OPTIONAL

- Vacuum packing bags
- External vacuum kit for Vac-Norm, containers and accessories
- Bag cutting kit
- Support for liquid packaging
- Additional filling plates

## ACCESSORIES

- Bag cutting kits
- Filling plates
- Liquid insert plates
- Vac-norm external vacuum kits
- Vac-norm containers
- Smooth bags for vacuum packing
- Trolley for vacuum packing machines

## SPECIFICATIONS

Pump capacity: 20 m³/h  
 Pump capacity (60 Hz): 20 m³/h  
 Bar length: 555 mm  
 Total loading: 750 W  
 Vacuum pressure (maximum): 2 mbar  
 Electrical supply: 230 V / 50-60 Hz / 1 ~ (5.5 A)

### Internal dimensions

- ✓ Width: 568 mm
- ✓ Depth: 431 mm
- ✓ Height: 215 mm

### External dimensions (WxDxH)

- ✓ Depth: 552 mm
- ✓ Height: 513 mm (230V) / [v:dim\_ext\_alto\_2] (120V)
- ✓ Width: 634 mm
- ✓ Depth: 552 mm
- ✓ Height: 513 mm

Net weight: 70.4 Kg

Noise level (1m.): 75 dB(A)  
 Background noise: 32 dB(A)

### Crated dimensions

786 x 612 x 685 mm  
 Gross weight: 79.8 Kg

FOOD PRESERVATION AND SOUS-VIDE  
VACUUM PACKING MACHINES · SENSOR LINE

product sheet  
updated 04/07/2023



SAMMIC S.L.  
Basiglio, 1 - 20129 AZCOITTA  
www.sammic.com



# VACUUM PACKING MACHINE SE-520 L 230/50-60/1

Tabletop model. 20 m<sup>3</sup>/h. 555 mm



1141143

FOOD PRESERVATION AND SOUS-VIDE  
VACUUM PACKING MACHINES · SENSOR LINE

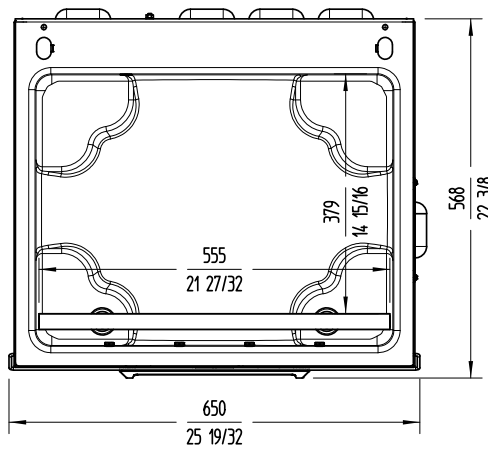
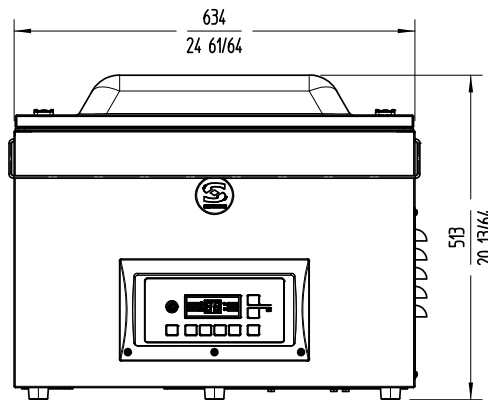
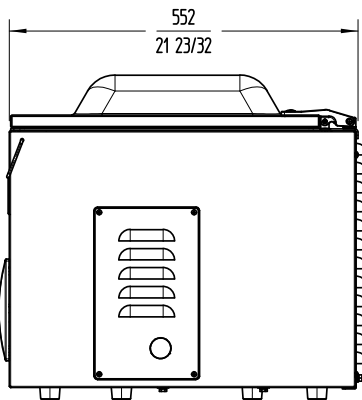

**www.sammic.co.uk**  
**Food Service Equipment Manufacturer**  
 Unit 2, Trevanah Road  
 Troon Industrial Park  
 LE4 9LS - Leicester  
 uksales@sammic.com  
 Tel.: +44 0116 246 1900



Project	Date
Item	Qty
Approved	

product sheet  
updated 04/07/2023