



VACUUM PACKING MACHINE SE-806 230-400/50/3N

Floorstanding unit. 63 m³/h. 530+848 mm.



1140680



SALES DESCRIPTION

Two sealing bars (530+848 mm.)
63 m³/h Busch vacuum pump.
Vacuum controlled by sensor.

- ✓ Powered by Busch.
- ✓ Vacuum controlled by sensor.
- ✓ Vacuum PLUS.
- ✓ Digital keyboard.
- ✓ Control panel equipped with display indicating the exact vacuum percentage.
- ✓ "Pause" button to marinate food.
- ✓ Safe liquid packing thanks to sensor control.
- ✓ Double seal.
- ✓ Cordless sealing bar.
- ✓ Bag-sealing programme.
- ✓ Pulse-controlled decompression.
- ✓ Vac-Norm ready with Automatic decompression.
- ✓ Stainless steel body and chamber.
- ✓ Damped transparent lid of highly durable polycarbonate.
- ✓ Dry-oil programme for drying the pump.
- ✓ Working hours counter for oil changes.
- ✓ Safety system with protection against vacuum failure.
- ✓ NSF-listed.

INCLUDES

- ✓ Sensor controls.
- ✓ Up to 10 seconds of extra vacuum pull.
- ✓ Soft air function.
- ✓ Dry oil cycle.
- ✓ BUSCH pump.
- ✓ NSF approved.
- ✓ Clear methacrylate lid.
- ✓ Filling plate.

OPTIONAL

- Vacuum packing bags.
- External vacuum kit for Vac-Norm, containers and accessories.
- Bag cutting kit.
- Support for liquid packaging.
- Additional filling plates.

ACCESSORIES

- Bag cutting kits
- Filling plates
- Liquid insert plates
- Vac-norm external vacuum kits
- Vac-norm containers
- Smooth bags for vacuum packing

SPECIFICATIONS

Pump capacity: 63 m³/h
 Pump capacity (60 Hz): 75 m³/h
 Bar length: 530 mm + 848 mm
 Total loading: 1500 W
 Vacuum pressure (maximum): 0.5 mbar
 Electrical supply: 400 V-230 V / 50 Hz / 3N ~ (7.2 A)
 Plug: --
 Electrical connection: 3P+N+G

Internal dimensions

- ✓ Width: 864 mm
- ✓ Depth: 603 mm
- ✓ Height: 215 mm

External dimensions (WxDxH)

- ✓ Width: 960 mm
- ✓ Depth: 757 mm
- ✓ Height: 998 mm

Net weight: 232 Kg

Noise level (1m.): 75 dB(A)
 Background noise: 32 dB(A)

Crated dimensions

840 x 1060 x 1200 mm
 Gross weight: 273 Kg

FOOD PRESERVATION AND SOUS-VIDE
VACUUM PACKING MACHINES · SENSOR LINE

product sheet
updated 07/11/2022





VACUUM PACKING MACHINE SE-806 230-400/50/3N

Floorstanding unit. 63 m³/h. 530+848 mm.



1140680

FOOD PRESERVATION AND SOUS-VIDE
VACUUM PACKING MACHINES · SENSOR LINE

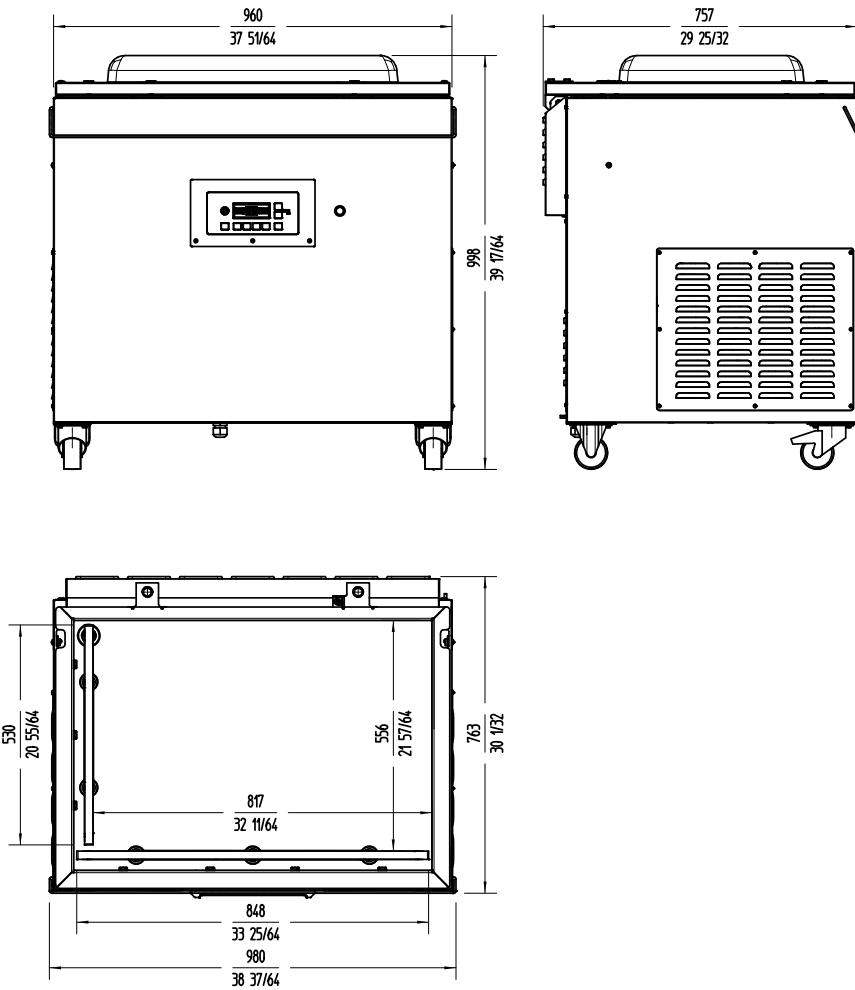

www.sammic.co.uk

Food Service Equipment Manufacturer

Unit 2, Trevanah Road
Troon Industrial Park
LE4 9LS - Leicester

uksales@sammic.com
Tel.: +44 0116 246 1900

Project	Date
Item	Qty
Approved	

product sheet
updated 07/11/2022