



# VACUUM PACKING MACHINE SU-420P 230/50-60/1

Tabletop model. 20 m<sup>3</sup>/h. 420 mm.



1140774



## SALES DESCRIPTION

420 mm. sealing bar.  
20 m<sup>3</sup>/h Busch vacuum pump.  
Vacuum controlled by sensor.

- ✓ Powered by Busch.
- ✓ Vacuum controlled by sensor.
- ✓ Vacuum PLUS.
- ✓ LCD colour screen: all information at a glance.
- ✓ Backlit touch keyboard.
- ✓ Programmable: 25-programme memory. Blocking option.
- ✓ "Pause" button.
- ✓ Phased vacuum programme.
- ✓ Detection of the evaporation of liquids.
- ✓ Double seal.
- ✓ Cordless sealing bar.
- ✓ Progressive decompression.
- ✓ Vac-Norm ready with Automatic decompression.
- ✓ Stainless steel body and chamber. Deep-drawn chamber.
- ✓ Damped transparent lid of high durability polycarbonate.
- ✓ Dry-oil programme for drying the pump.
- ✓ Working hours counter for oil changes.
- ✓ Safety system with protection against vacuum failure.

## INCLUDES

- ✓ BUSCH pump.
- ✓ Sensor Controls.
- ✓ 25 programmable settings.
- ✓ Vacuum PLUS: up to 10 seconds of extra vacuum pull.
- ✓ Soft air function.
- ✓ Clear methacrylate lid.
- ✓ "PAUSE" function.
- ✓ Liquid detection system.
- ✓ Dry oil cycle.
- ✓ NSF Approved.
- ✓ Filling plate.

## OPTIONAL

- Inert gas
- Sealing plus
- Printer
- Bluetooth connectivity
- Vacuum packing bags
- External vacuum kit for Vac-Norm, containers and accessories
- Support for liquid packaging
- Additional filling plates

## ACCESSORIES

- Bag cutting kits
- Filling plates
- Liquid insert plates
- Vac-norm external vacuum kits
- Vac-norm containers
- Smooth bags for vacuum packing
- Trolley for vacuum packing machines
- Thermal labels for CG2 / RB printer
- RB Desktop printer for SU vacuum packing machines
- Thermal transfer labels for RB printer

## SPECIFICATIONS

Pump capacity: 20 m<sup>3</sup>/h  
 Pump capacity (60 Hz): 24 m<sup>3</sup>/h  
 Bar length: 420 mm  
 Total loading: 750 W  
 Vacuum pressure (maximum): 2 mbar  
 Electrical supply: 230 V / 50-60 Hz / 1 ~ (5.5 A)  
 Plug: EU (SCHUKO 2P+G)

### Internal dimensions

- ✓ Width: 430 mm
- ✓ Depth: 415 mm
- ✓ Height: 180 mm

### External dimensions (WxDxH)

- ✓ Width: 484 mm
- ✓ Depth: 529 mm
- ✓ Height: 448 mm

Net weight: 56.7 Kg

Noise level (1m.): 75 dB(A)

Background noise: 32 dB(A)

### Crated dimensions

600 x 600 x 610 mm

Gross weight: 63 Kg

FOOD PRESERVATION AND SOUS-VIDE  
VACUUM PACKING MACHINES - "SENSOR ULTRA" LINE

product sheet  
updated 19/05/2022



SAMMIC, S.L.  
Bassate, 1 - 20729 A2KOITIA  
www.sammic.com



# VACUUM PACKING MACHINE SU-420P 230/50-60/1

Tabletop model. 20 m<sup>3</sup>/h. 420 mm.



1140774

FOOD PRESERVATION AND SOUS-VIDE  
VACUUM PACKING MACHINES - "SENSOR ULTRA" LINE

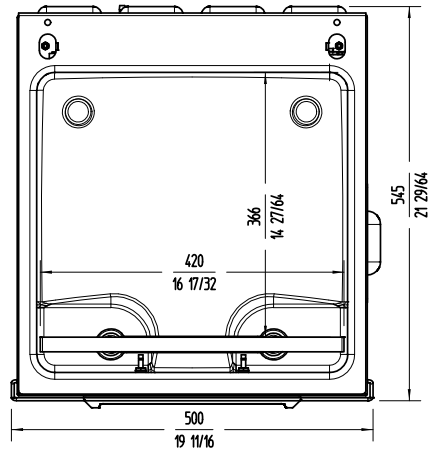
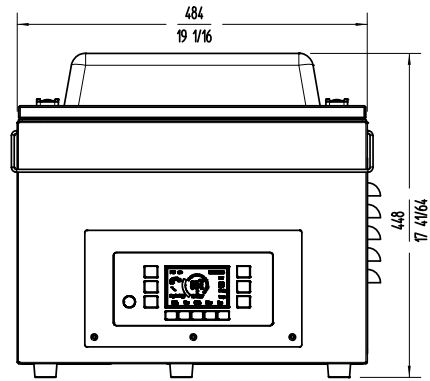
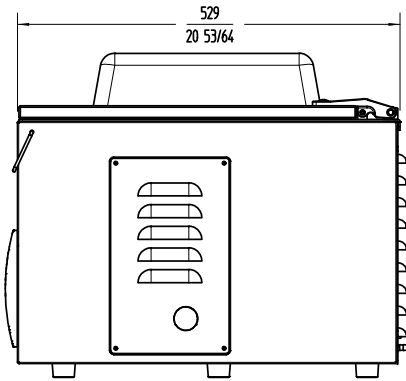

**www.sammic.co.uk**  
**Food Service Equipment Manufacturer**  
 Unit 2, Trevanah Road  
 Troon Industrial Park  
 LE4 9LS - Leicester  
 uksales@sammic.com  
 Tel.: +44 0116 246 1900



Project	Date
Item	Qty
Approved	

product sheet  
updated 19/05/2022