



VACUUM SEALER SU-316

Tabletop model. 16 m³/h. 320 mm.



SALES DESCRIPTION

320 mm. sealing bar.
16 m³/h Busch vacuum pump.
Vacuum controlled by sensor.

- ✓ Powered by Busch.
- ✓ Vacuum controlled by sensor.
- ✓ Vacuum PLUS.
- ✓ LCD colour screen: all information at a glance.
- ✓ Backlit touch keyboard.
- ✓ Programmable: 25-programme memory. Blocking option.
- ✓ "Pause" button.
- ✓ Phased vacuum programme.
- ✓ Detection of the evaporation of liquids.
- ✓ Double seal.
- ✓ Cordless sealing bar.
- ✓ Progressive decompression.
- ✓ Vac-Norm ready with Automatic decompression.
- ✓ Stainless steel body and chamber. Deep-drawn chamber.
- ✓ Damped transparent lid of high durability polycarbonate.
- ✓ Dry-oil programme for drying the pump.
- ✓ Working hours counter for oil changes.
- ✓ Safety system with protection against vacuum failure.
- ✓ NSF-listed model.

INCLUDES

- ✓ BUSCH pump.
- ✓ Sensor Controls.
- ✓ 25 programmable settings.
- ✓ Vacuum PLUS: up to 10 seconds of extra vacuum pull.
- ✓ Soft air function.
- ✓ Clear methacrylate lid.
- ✓ "PAUSE" function.
- ✓ Liquid detection system.
- ✓ Dry oil cycle.
- ✓ NSF Approved.
- ✓ Filling plate.

OPTIONAL

- Inert gas
- Sealing plus
- Printer
- Bluetooth connectivity
- Vacuum packing bags
- External vacuum kit for Vac-Norm, containers and accessories
- Support for liquid packaging
- Additional filling plates

ACCESSORIES

- Filling plates
- Liquid insert plates
- Vac-norm external vacuum kits
- Vac-norm containers
- Smooth bags for vacuum packing
- Trolley for vacuum packing
- machines
- Thermal labels for CG2 / RB printer
- RB Desktop printer for SU vacuum packing machines
- Thermal transfer labels for RB printer

SPECIFICATIONS

Pump capacity: 16 m³/h
 Pump capacity (60 Hz): 19 m³/h
 Bar length: 320 mm
 Total loading: -- W
 Vacuum pressure (maximum): 2 mbar

Plug: --

Internal dimensions

- ✓ Width: 330 mm
- ✓ Depth: 360 mm
- ✓ Height: 155 mm

External dimensions (WxDxH)

- ✓ Width: 384 mm
- ✓ Depth: 465 mm
- ✓ Height: 403 mm

Net weight: 42 Kg

Noise level (1m.): 75 dB(A)

Background noise: 32 dB(A)

FOOD PRESERVATION AND SOUS-VIDE
VACUUM PACKING MACHINES - "SENSOR ULTRA" LINE

product sheet
updated 04/03/2022



SAMMIC, S.L.
Basaite, 1 - 20720 Azzovita
www.sammic.com



VACUUM SEALER SU-316

Tabletop model. 16 m³/h. 320 mm.



AVAILABLE MODELS

1140742	Vacuum packing machine SU-316 230/50-60/1
1140743	Vacuum packing machine SU-316G 230/50-60/1
1140744	Vacuum packing machine SU-316P 230/50-60/1
1140745	Vacuum packing machine SU-316+ 230/50-60/1
1140746	Vacuum packing machine SU-316P+ 230/50-60/1
1140747	Vacuum packing machine SU-316GP 230/50-60/1
1140748	Vacuum packing machine SU-316G+ 230/50-60/1
1140749	Vacuum packing machine SU-316GP+ 230/50-60/1
1140751	Vacuum packing machine SU-316 120/50-60/1
1140752	Vacuum packing machine SU-316G 120/50-60/1
1140753	Vacuum packing machine SU-316P 120/50-60/1
1140754	Vacuum packing machine SU-316+ 120/50-60/1
1140755	Vacuum packing machine SU-316P+ 120/50-60/1 (with PLUS welding option)
1140756	Vacuum packing machine SU-316GP 120/50-60/1
1140757	Vacuum packing machine SU-316G+ 120/50-60/1
1140758	Vacuum packing machine SU-316GP+ 120/50-60/1

* Ask for special versions availability

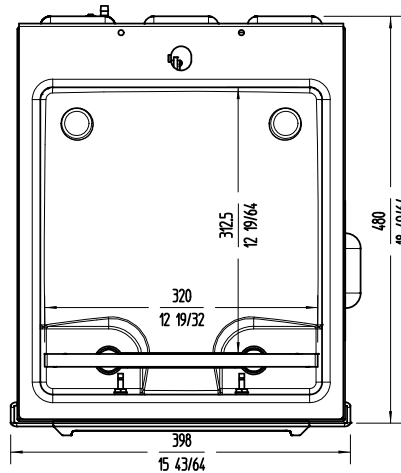
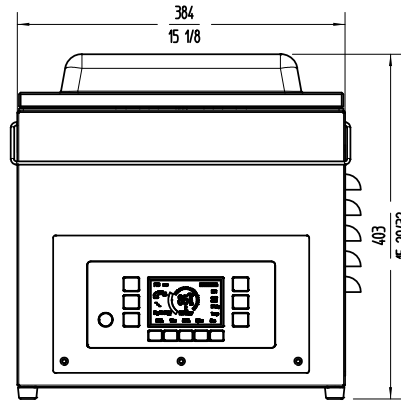
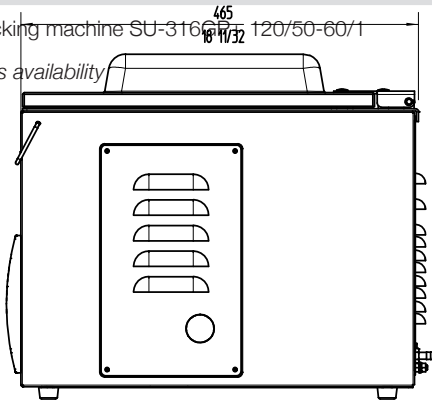

FOOD PRESERVATION AND SOUS-VIDE
VACUUM PACKING MACHINES - "SENSOR ULTRA" LINE



www.sammic.co.uk

Food Service Equipment Manufacturer

Unit 2, Trevanth Road
Troon Industrial Park
LE4 9LS - Leicester

uksales@sammic.com
Tel.: +44 0116 246 1900



Project	Date
Item	Qty
Approved	

product sheet
updated 04/03/2022