



# F900

## *E9342 Twin Pan Electric Fryer*

### Key features

- Two independently-controlled pans
  - Only use one pan during quiet service periods
  - Ideal for confidently producing allergen free food
- Oil capacity is just 7.5 litres per pan
  - Rapid heat up and recovery
- Elements rotate within pan
  - Makes cleaning easy
- Manual controls
  - Simple and ease to use
- Eco setting and fat melt mode
  - Reduces power consumption during pre-heating
- IPX5 rated
  - Easy and problem-free cleaning
- Supplied with fish grids, lid and oil bucket, filter mesh and basket
  - Everything you need to operate the fryer
- Stainless steel panels with Scotch Brite finish
  - Looks great, ideal for front-of-house kitchens
- Dynamic Link System compatible
  - Integrated linking system allows quick and easy installation to create a seamless, continuous cookline

### Accessories

- Front hob rail
- Kick strip
- Rear blanking plate
- Side hob extension
- Factory fitted, adjustable castors



### Similar Models

- E9342B2 twin pan fryer with two drain buckets
- E9342F twin pan fryer with filtration
- E9342F2 twin pan fryer with twin filtration

## Twin Pan Electric Fryer

Measurements *in mm*

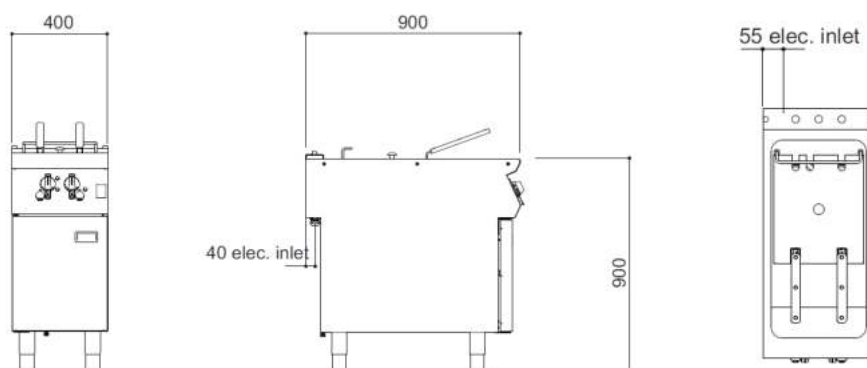

Unit on castors is the same hob height

## Specification *details*

Electrical rating (kW)	15	
Electrical supply voltage	400V 3N~ 50/60 Hz	
Required electrical supply (A)	32	
Electrical current split (A)	L1: 21.74, L2: 21.74, L3: 21.74	
Element rating (kW)	7.5	
Oil capacity (litres)	7.5	
Chip Output (kg/hr)	23	
Weight (kg)	65	
Packed weight (kg)	75	
Packed dimensions (w x d x h - mm)	490 x 1000 x 1015	
GTIN number	On feet	On Castors

## Short Form *specification*

Unit to be Falcon F900 Series high performance electric twin pan fryer. Pans will be 304 grade stainless steel. Unit to be supplied upon adjustable feet with a working oil capacity of 7.5 litres (per pan).

The pan will be of open well design to allow easy cleaning of the pan. Baskets to be positioned at pan rear for oil drain off and storage.

Oil to be drained from pans into oil bucket that is to be self-contained inside the unit base. The oil temperature will be thermostatically controlled via precise controls from 130-185°C. The unit will have safety thermostats fitted as standard to prevent unit from overheating.

The hob will be constructed from 2mm 304 grade stainless steel. Hobs will be laser cut with right-angled edges to allow joining of units with no gaps between hobs. Exterior panels are Scotch Brite finish stainless steel. Control knobs to be marked showing temperature positions and to have a bezel behind each knob to prevent water ingress.

## Installation note

Please consult local legislation with regard to installation of cooking equipment.

